

REESE

You *can* take it with you.

INSTRUCTION & OPERATION MANUAL

20K - Fifth Wheel Hitch

DEALER/INSTALLER:

- (1) Provide this Manual to end user.
- (2) Physically demonstrate hitching and unhitching procedures in this Manual to end user.
- (3) Have end user demonstrate that he/she understands procedures.

END USER:

- (1) Read and follow this Manual every time you use hitch.
- (2) Save this Manual and Hitch Warning Hang Tag for future reference.
- (3) Pass on copies of Manual and Hitch Warning Hang Tag to any other user or owner of hitch.
- (4) Never remove hitch warning decals as shown on the cover of this manual. If damaged, contact Cequent Performance Products (1-800-632-3290) for free replacement.

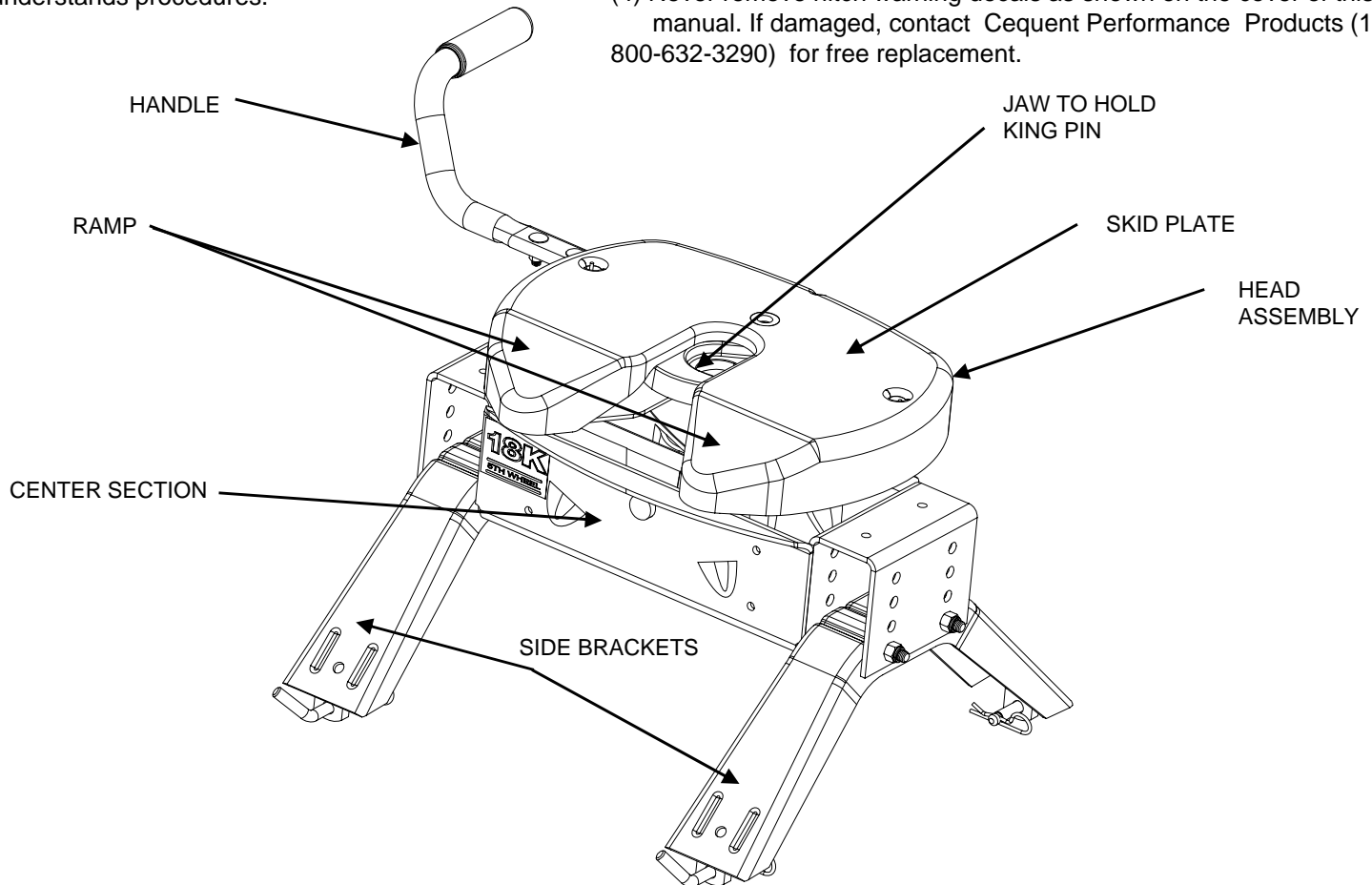

⚠ WARNING:

Failure to follow all of these instructions may result in death or serious injury

INDEX

| | |
|-------------------------------------------------------------------|-------|
| 1. ASSEMBLY INSTRUCTIONS | |
| 2. BEFORE EACH TRIP | P. 2 |
| 3. HITCHING PROCEDURE | P. 3 |
| 4. PULL TEST | P. 6 |
| 5. UNHITCHING PROCEDURE | P. 6 |
| 6. MAINTENANCE | P. 7 |
| 7. FIVE YEAR LIMITED WARRANTY | P. 9 |
| 8. APPENDIX A (Guidelines for matching hitch, truck, and trailer) | P. 10 |
| 9. APPENDIX B (Guideline for center section orientation) | P. 14 |

For Installation Assistance or Technical Help, Call 1-888-521-0510

⚠ WARNING:

Do Not use this hitch for towing a trailer with a pin box that could come into contact with or interfere with the latch for the hitch handle when turning! (See Fig. A) If the pin box contacts the hitch handle or its latch when turning, the trailer may become unhitched.

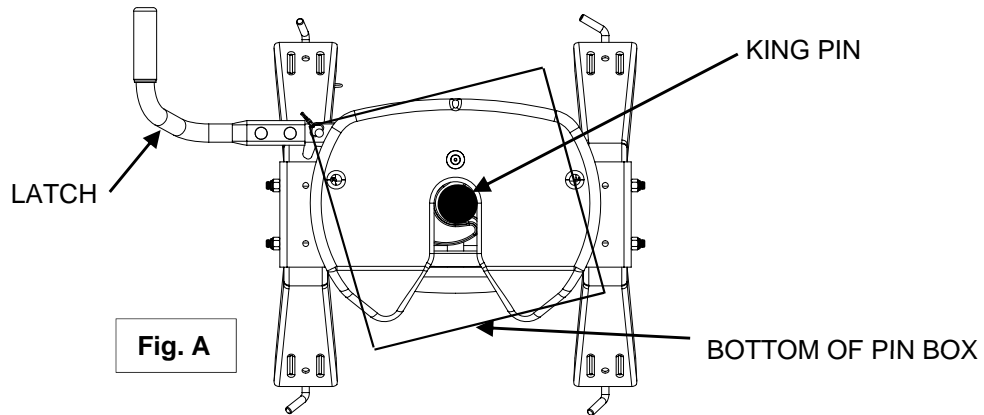

ASSEMBLY INSTRUCTIONS

⚠ WARNING:

- Connection for trailer wiring should be in the side of the truck bed between the driver's seat and the wheel well for the back truck axle
- Installation of connection rearward of the wheel well may result in user placing body between truck and trailer. **WHENEVER POSSIBLE, AVOID PUTTING BODY UNDER TRAILER OR BETWEEN TRUCK AND TRAILER!**
- If you need to place any part of your body under trailer or between truck and trailer:
 - All trailer tires **MUST** be blocked in front and behind each tire **AND**
 - Trailer landing gear **MUST** be resting on firm ground **AND**
 - Truck **MUST** be stationary, in park, with emergency brake on!

1. Reference Fig. 11 on page 8.
2. 5th Wheel Kit is contained in three cartons. Unpack and become familiar with parts on parts list. Base rails, brackets and hardware are in separate kit (part no. 30035) with separate Installation Instructions for Fifth Wheel Rail Mounting Kit.
3. Place two base rails across bed of truck (See Fig. B). Select one side bracket and place tabs through the centermost rectangular slot in the base rails. Slip long pull pins through holes in base rails. Repeat. Secure pull pins with spring retaining clips.

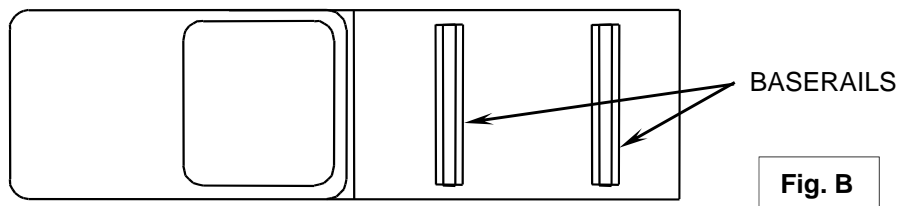

4. Select 20K Center Section and install on leg aligning holes for hitch height desired. (Lowest position 13" highest 17"). Install four 1/2-13 x 4.5" Hex bolts, (with heads toward inside as shown) and lock nuts. (See Appendix B for center section orientation)
5. Torque 1/2" nuts to 75 lb. ft.
6. Install base rails and mounting brackets as described in "Installation Instructions for 5th Wheel Rail Mounting Kit," Part # 30035.

⚠ WARNING

Base rails must be bolted through the floor of the pickup to the brackets that attach to the truck frame. DO NOT INSTALL BY FASTENING TO THE FLOOR OF THE PICKUP BOX ONLY. The floor alone is not strong enough to carry the loads imposed by the trailer.

GUIDELINES FOR MATCHING HITCH TRUCK AND TRAILER

If preparing to tow a 5th wheel trailer which you have not rating checked previously, please consult Appendix A of 5th Wheel Kit assembly instructions.

BEFORE EACH TRIP:

1. Lubricate skid plate surface of the hitch and pivot pin grease fitting (see Figure on cover of Manual) with automotive type chassis grease or use a plastic lube plate to provide a lubricated surface. Use lithium grease to lubricate pivot points of moving parts within the hitch.
2. Plastic lube plates (Performance Products No. 83001/40001) can be used to avoid messy grease. The plastic lube plate must not exceed 3/16 of an inch in thickness to ensure hitch will operate properly. **Lube plates must be 12 inches in diameter or larger to properly distribute king pin weight.**
3. Before each trip or maneuver, operate the handle and check that the jaw opens and closes freely.
4. See that all hitch pull pins (#7 (P/N 30434) & #12 (P/N 110974), Figure 11) are in place and the spring retaining clips (#4, Figure 11) are installed (Figure 1). Note that hitch pull pins used to attach the head assembly to the center section for the 5th Wheel Kit Hitch are 90 degree bent pins and if replacements are needed, please contact Customer Service at (800) 632-3290. Check that all four anchor assembly pins are pinned and have the retaining clips attached.

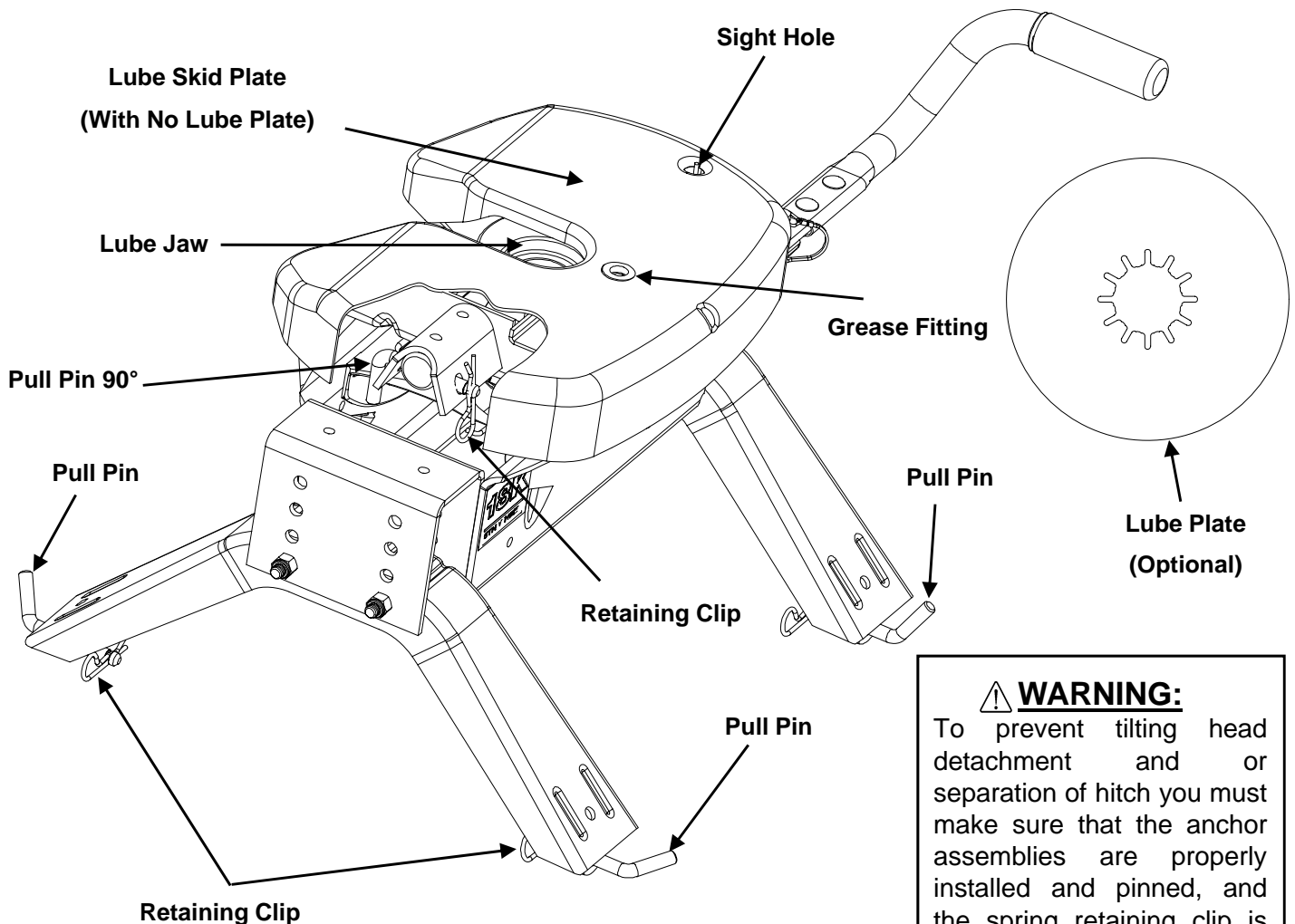

⚠ WARNING:
To prevent tilting head detachment and or separation of hitch you must make sure that the anchor assemblies are properly installed and pinned, and the spring retaining clip is properly installed onto the 1/2" pull pin before towing. The spring retaining clip can easily be seen through the site holes in the top of the head.

Figure 1 : Pin and Clip (Skid Plate cut away view)

HITCHING PROCEDURE:

IMPORTANT: YOU ARE RESPONSIBLE FOR SAFE HITCHING AND UNHITCHING OPERATIONS. DO NOT RELY ON OTHERS TO PERFORM THESE DUTIES. YOU MUST PERSONALLY MAKE SURE THE FOLLOWING STEPS ARE PERFORMED IN THE FOLLOWING ORDER!

⚠ WARNING:
FAILURE TO FOLLOW THESE INSTRUCTIONS MAY RESULT IN DEATH OR SERIOUS INJURY.

1. Place blocks (sometimes called "chocks") firmly against front and rear of each trailer wheel to prevent any possible forward or rearward motion. **DO NOT REMOVE BLOCKS UNTIL EACH OF THE FOLLOWING STEPS AND THE PULL TEST HAVE BEEN COMPLETED.** Lower tailgate if necessary. Clearance of the lowered tailgate to the trailer needs to be monitored during hookups as some manufacturer combinations of truck and trailer have little or no clearance.
2. Using trailer jacks, adjust trailer height following the directions in the trailer manual so that bottom of trailer pin box ("A" in Figure 2) is $\frac{1}{2}$ to 1 inch below skid plate (See "B" in Figure 2). During the hitching maneuver, the bottom of the trailer pin box should come in contact with skid plate ramp ("C" in Figure 2).

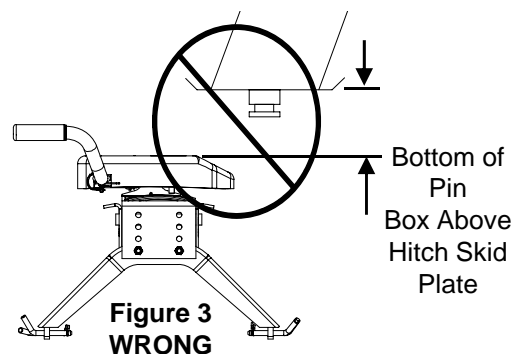
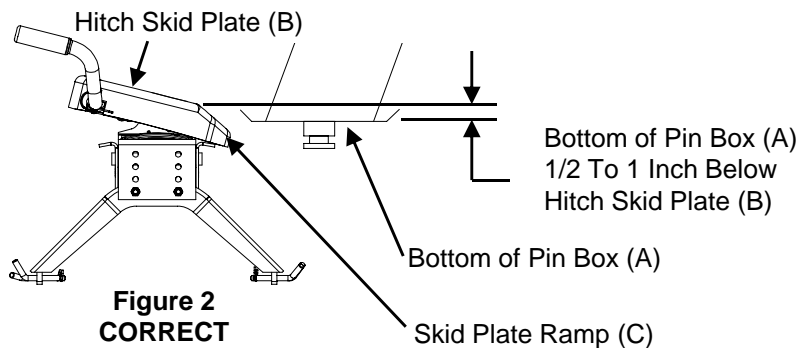

⚠ WARNING:

Failure to follow this instruction may result in king pin being too high and coming to rest on top of the closed jaw or not completely inside jaw. (See Figure 6 & 7). This could result in trailer separating from hitch. Trailer separation may result in death or serious injury if anyone is under the trailer or between truck and trailer when separation occurs.

3. Remove bail pin from bail pin hole (see Figure 4). Then pull handle out and rearward to hold open

NOTE: Hitch jaw must be in the open position for king pin to enter the hitch.

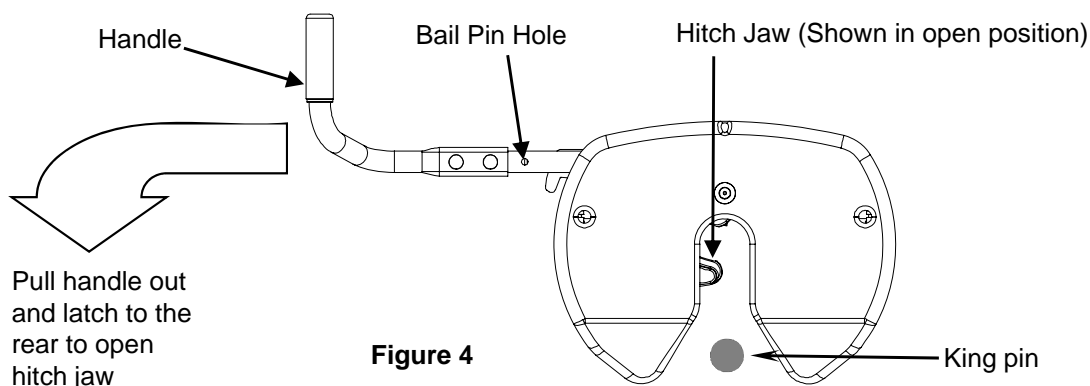

4. With handle in the open position (See Figure 4), back truck slowly into trailer. As king pin completely enters head, jaw will spring closed around king pin and handle will return to the closed position. If the handle does not return to the closed position, then try to push the handle back to the closed position. If handle does not return to the closed position then move the truck slightly forward or rearward until the handle returns to the closed position. (See Figure 5)

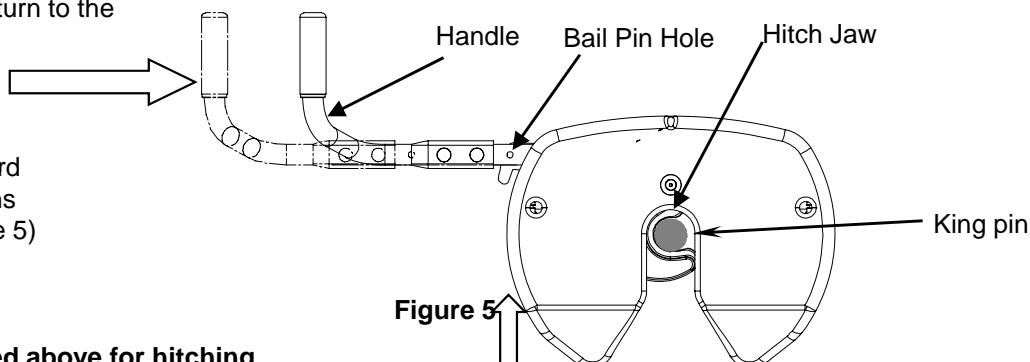

5. Use **only** the method described above for hitching.

6. With all trailer wheels still firmly blocked, landing gear still resting on firm ground and supporting trailer weight, and truck stationary and in park with emergency brake on: visually check that bottom of pin box is resting on top of the hitch. **THERE SHOULD BE NO SPACE BETWEEN THESE SURFACES** (see Figure 6). If space exists, (see Figure 7) trailer has not been properly hitched. **DO NOT TOW!** Instead, repeat above steps until trailer is properly hitched. **DO NOT PLACE BODY UNDER TRAILER TO PERFORM THIS INSPECTION!**

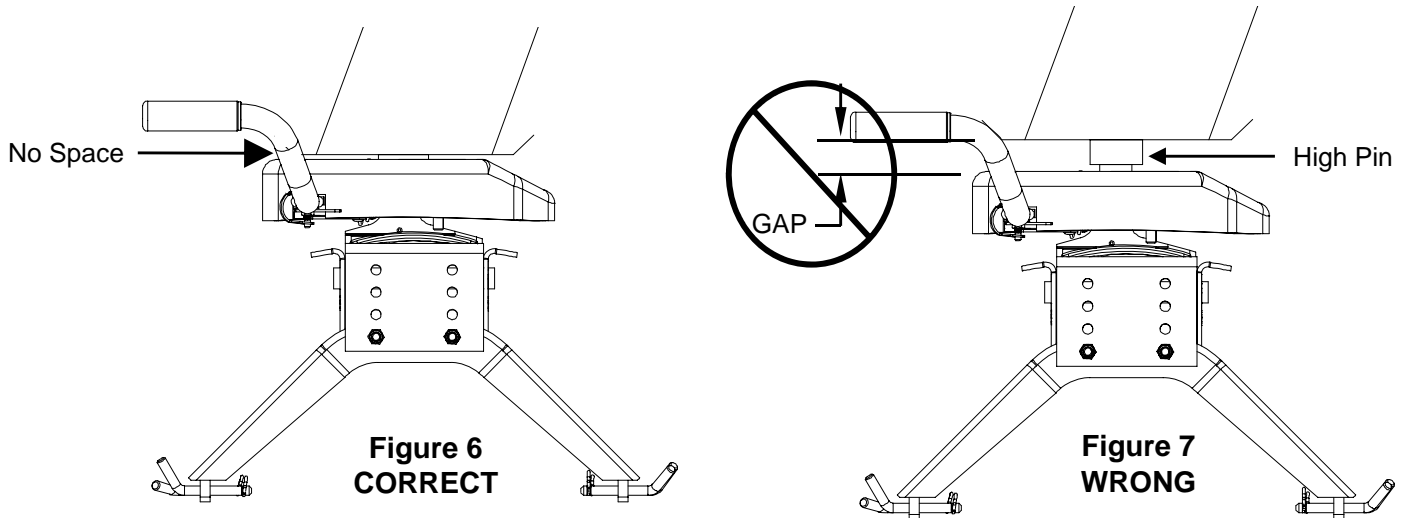

7. Place bail pin through bail pin holes in the handle and the base plate to make sure the hitch jaw is locked closed. **IF FLAG BLOCKS HOLE FOR BAIL PIN, TRAILER HAS NOT BEEN PROPERLY CONNECTED TO HITCH. DO NOT TOW!** Repeat above steps until trailer is properly hitched. (see Figure 8)

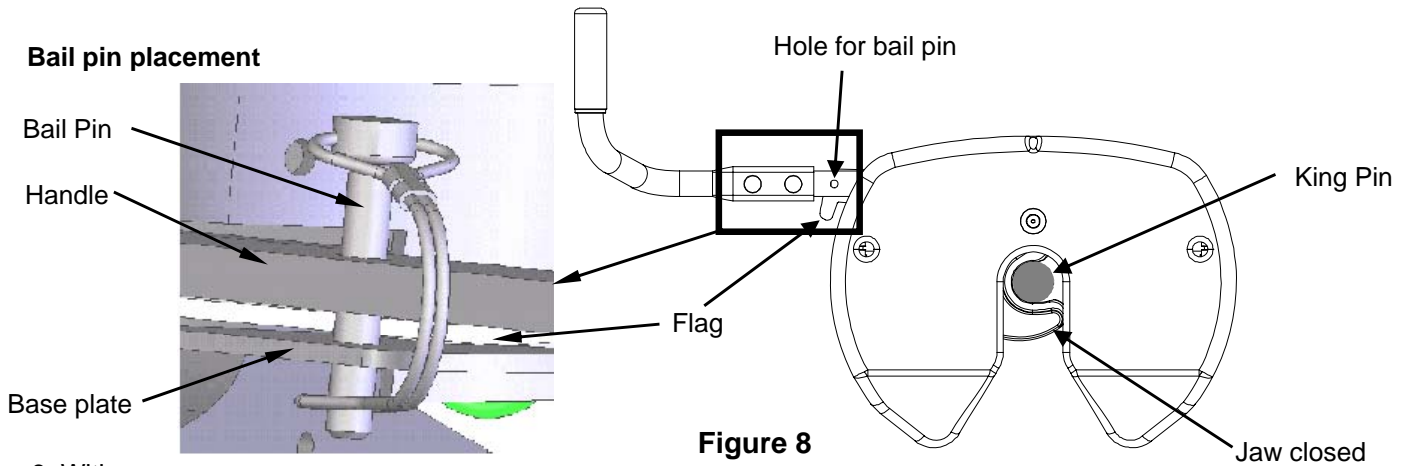

8. With:

- All trailer wheels still firmly blocked in front and behind each tire, and
- Truck stationary with the emergency brake on, and
- Trailer landing gear still resting on firm ground and supporting trailer weight; and

Connect electrical cable between truck and trailer, connect breakaway switch cable from pin box to a permanent part of truck, and raise tailgate of truck. Do not tow trailer until the Pull Test has been successfully completed.

⚠ WARNING:

Do not attempt to hitch by using trailer jacks to lower trailer and king pin. This could result in king pin coming to rest on top of skid plate instead of within hitch opening where jaws are located. King pin could slide off hitch and trailer could drop, resulting in death or serious injury (see Figure 9).

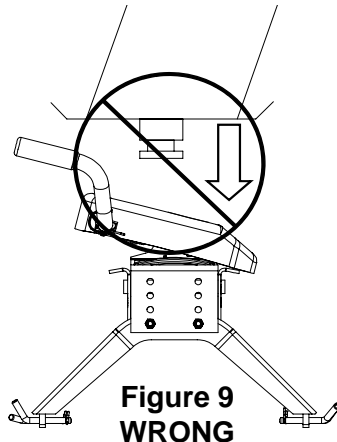

⚠ WARNING:

- Connection for trailer wiring should be in the side of the truck bed between the driver's seat and the wheel well for the back truck axle
- Installation of connection rearward of the wheel well may result in user placing body between truck and trailer. **WHENEVER POSSIBLE, AVOID PUTTING BODY UNDER TRAILER OR BETWEEN TRUCK AND TRAILER!**
- If you need to place any part of your body under trailer or between truck and trailer:

- All trailer tires **MUST** be blocked in front and behind each tire **AND**
- Trailer landing gear **MUST** be resting on firm ground **AND**
- Truck **MUST** be stationary, in park, with emergency brake on!

PULL TEST

⚠ WARNING:

Failure to perform pull test may result in death or serious injury

1. With all trailer wheels still firmly blocked, and
2. Trailer landing gear still resting on firm ground and supporting trailer weight and,
3. Truck stationary and with emergency brake on:
4. Make sure no one is between truck and trailer, Return to cab of truck and release truck's emergency brake. Apply trailer brakes. Try to pull trailer slowly forward with the truck. If the trailer is properly hitched, the wheel blocks and trailer brakes should keep the truck from moving forward.

NOTE: If trailer is not properly hitched, trailer will separate from hitch and truck will move forward leaving trailer behind. If you followed all previous steps, the trailer will not drop or fall and you will easily be able to repeat the attachment steps.

⚠ WARNING:

Failure to keep wheels blocked and landing gear down could result in trailer suddenly moving or falling. This could result in death or serious injury!

5. After successfully performing above steps, fully raise trailer landing gear (see trailer manual).
6. Check and inspect all electrical circuits for proper operation. (Clearance lights, turn signals, stop lights, etc.).
7. Remove and store all trailer wheel blocks.

UNHITCHING PROCEDURE:

PERFORM THE FOLLOWING IN THIS ORDER:

1. Make sure truck is in park with emergency brake on.
2. Place blocks firmly against front and rear of each trailer wheel to prevent any possible forward or rearward motion.
3. Using trailer jacks, lower trailer landing gear following the directions in the Trailer Manual until feet of landing gear are resting on firm ground.

⚠ WARNING:

Trailers that are not stable or properly hitched can fall and cause death or serious injury
To avoid death or serious injury:

- All trailer tires **MUST** be blocked in front and behind each tire **AND**
- Trailer landing gear **MUST** be resting on firm ground **AND**
- Truck **MUST** be stationary, in park, with emergency brake on!

4. Lower truck tail gate.
5. Disconnect power cable and breakaway switch cable between truck and trailer.
6. Remove bail pin from hole in handle.
7. Pull hitch handle out completely until it latches in open position so that king pin is no longer securely grasped by hitch jaws (see Figure 4). Trailer is now free from hitch and truck. If handle does not pull out, there is probably pressure against the jaw. To relieve this pressure, back the truck slightly or pull the truck slightly forward. Reset truck emergency brake. Then pull hitch handle out completely until it latches in open position.
8. AFTER MAKING CERTAIN NO ONE IS STANDING BETWEEN TRUCK AND TRAILER OR IN FRONT OF TRUCK, drive truck slowly away from trailer.

⚠ WARNING

Whenever possible, avoid putting body under trailer or between truck and trailer
If you need to place any part of our body under trailer or between truck and trailer:

- All trailer tires **MUST** be blocked in front and behind each tire **AND**
- Trailer landing gear **MUST** be resting on firm ground **AND**
- Truck **MUST** be stationary, in park, with emergency brake on!

9. Hitch jaw will automatically close as the king pin is removed from the jaw.
10. KEEP WHEEL BLOCKS IN PLACE. This will keep trailer from moving unexpectedly

MAINTENANCE:

1. Recheck tightness of all hardware every 1000 miles of use. All 1/2" bolts have a torque specification of 75ft.lbs.
2. See "Before each trip" section in this manual.
3. **Head assembly to center section should be lubed every 12 months with grease to keep assemblies moving freely.**

⚠ WARNING:

Tilting 5th Wheel head can crush and cut. Keep hands and fingers clear from this area at all times (including placement/removal of head).

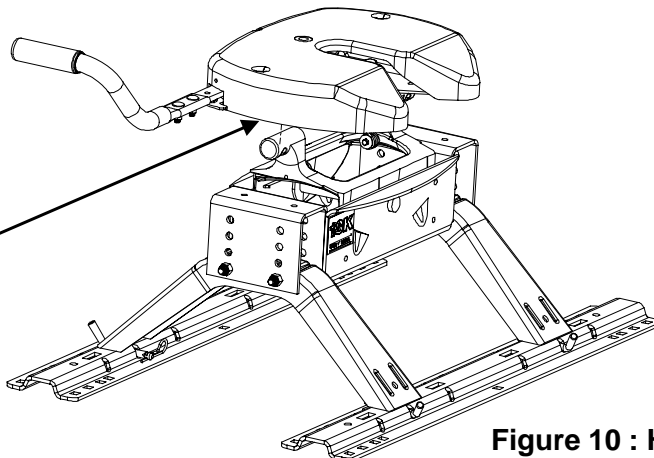

Figure 10 : Head Placement

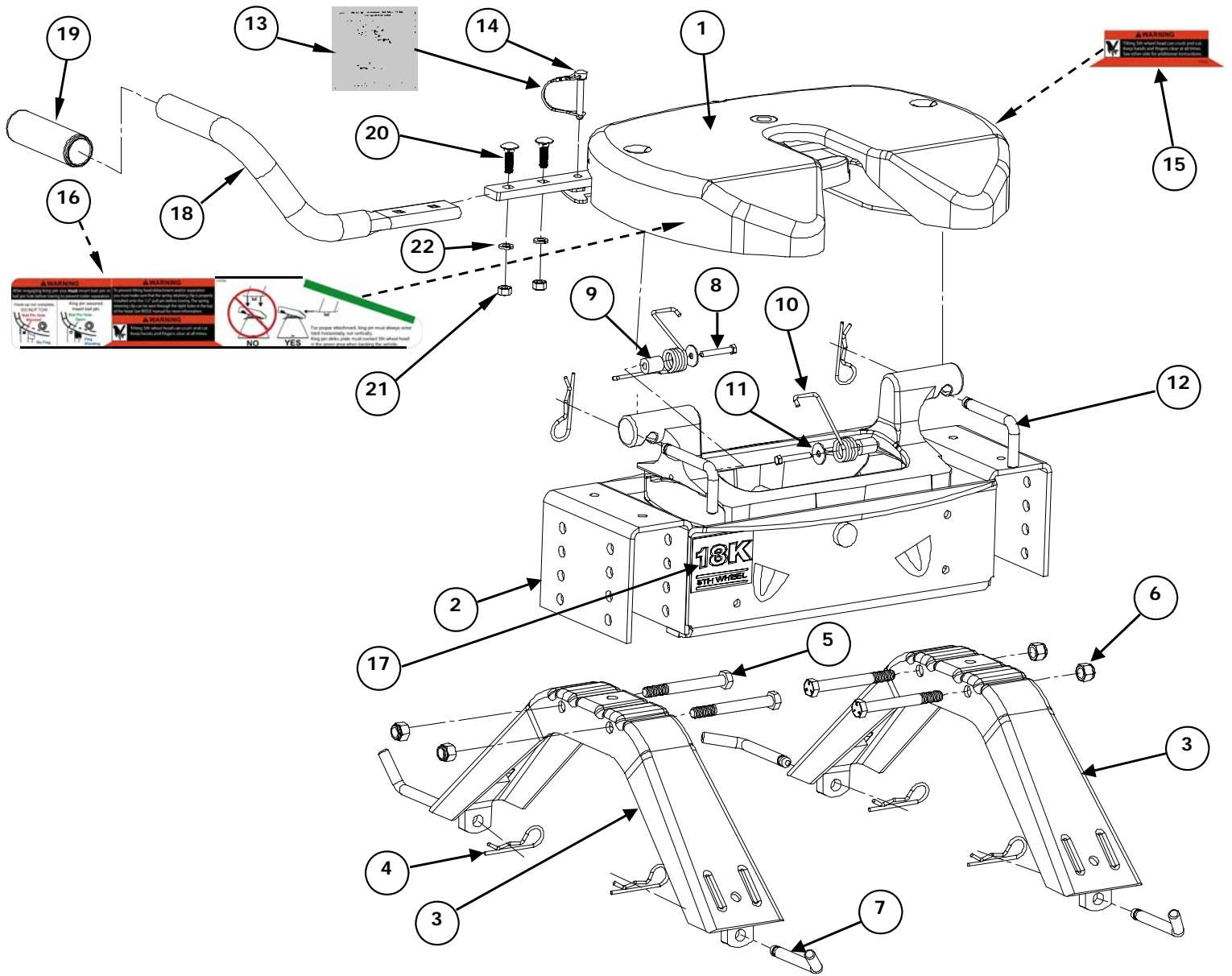

Figure 11

| REF # | QTY. | DESCRIPTION |
|-------|------|-------------------------------------------|
| 1 | 1 | 18K HEAD ASSEMBLY |
| 2 | 1 | 18K CENTER SECTION |
| 3 | 2 | SIDE BRACKET (P/N 30834) |
| 4 | 6 | RETAINCLIP (P/N 55515) |
| 5 | 4 | 1/2" X 4 1/2" BOLTS (P/N 01150018) |
| 6 | 4 | 1/2" LOCK NUTS (P/N 3376) |
| 7 | 4 | 1/2" DIA LONG PULL PIN (P/N 30434) |
| 8 | 2 | 1/4" X 20 - 1.75 HX HEAD BOLT (P/N 55256) |
| 9 | 2 | TUBE SPACER (P/N 110898) |
| 10 | 2 | TORSION SPRING (P/N 110787 & 110788) |
| 11 | 2 | 1/4" WASHER (P/N 55546) |
| 12 | 2 | 1/2" PULL PIN 90° (P/N 110974) |

| REF # | QTY | DESCRIPTION |
|-------|-----|---------------------------------------|
| 13 | 1 | HANG TAG (P/N 110795) |
| 14 | 1 | BAIL PIN WITH LANYARD (P/N 110896) |
| 15 | 1 | LABEL, PINCH POINT (P/N 110954) |
| 16 | 1 | LABEL, OPERATION WARNING (P/N 110793) |
| 17 | 2 | LABEL, RATING (P/N 113145) |
| 18 | 1 | HANDLE TUBE (P/N 110470) |
| 19 | 1 | HANDLE GRIP (P/N 07417) |
| 20 | 2 | 3/8 CARRIAGE BOLT (P/N 01246005) |
| 21 | 2 | 3/8 NUT (P/N 55052) |
| 22 | 2 | 3/8 LOCK WASHER (P/N 01129006) |

NOTES

FIVE YEAR LIMITED WARRANTY

Fifth Wheel Hitches

Cequent Performance Products warrants the 20K 5th Wheel Hitch from date of purchase against defects in material and workmanship under normal use and service, ordinary wear and tear excepted, for 5 years of ownership to the original consumer purchaser when a **Cequent Performance Products** mounting kit is used.

Cequent Performance Products will replace FREE OF CHARGE any part which proves defective in material or workmanship when presented to any **Cequent Performance Products** dealer, **Cequent Performance Products** Warehouse or returned to factory. TRANSPORTATION CHARGES PREPAID, at the address below. THIS WARRANTY IS LIMITED TO DEFECTIVE PARTS REPLACEMENT ONLY. LABOR CHARGES AND/OR DAMAGE INCURRED IN INSTALLATION OR REPLACEMENT AS WELL AS INCIDENTAL AND CONSEQUENTIAL DAMAGES CONNECTED THEREWITH ARE EXCLUDED.

Some states do not allow the exclusion or limitation of incidental or consequential damages, so the above limitation or exclusion may not apply to you.

Any damage to the 5th Wheel Hitch as a result of misuse, abuse, neglect, accident, improper installation, or any use violative of instructions furnished by us, WILL VOID THE WARRANTY.

This warranty gives you specific legal rights, and you may also have other rights which vary from state to state. In the event of a problem with warranty service or performance, you may be able to go to a small claims court, or a federal district court.

Cequent Performance Products, Inc.
2602 College Avenue
Goshen, IN 46528

Appendix A

GUIDELINES FOR MATCHING HITCH, TRUCK, AND TRAILER

GUIDELINES FOR MATCHING HITCH, TRUCK, AND TRAILER

⚠ WARNING:

Failure to follow all of these instructions may result in death or serious injury!

⚠ WARNING:

Failure to check and follow tow ratings could result in tow vehicle damage or truck and trailer separation while towing.

- Trailer and its contents together must not exceed truck, hitch and/or trailer tow ratings.
- Towing vehicle must have a manufacturer's rated towing capacity equal to or greater than the gross trailer weight (dry weight of the trailer plus payload of the trailer). (Figure 12)
- Gross weight of trailer must not exceed 18,000 pounds.
- King pin weight must not exceed 4,500 pounds (Figure 13). If in doubt have king pin weight measured by qualified facility.

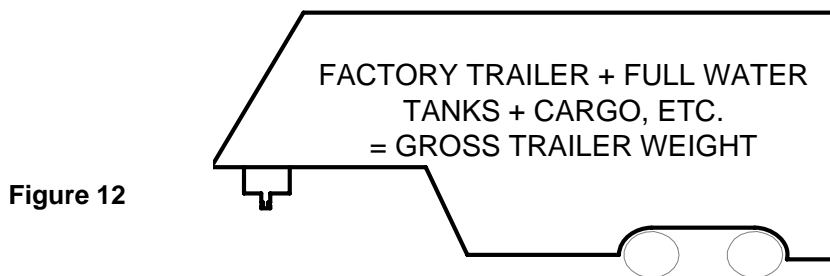

1. Check Tow Ratings:

Vehicle Tow Rating: _____.

5th Wheel Kit Hitch Rating: 20,000 lbs..

Gross Trailer Weight (Figure 12): _____.

***Trailer weight should be the lowest of these recorded ratings for safe towing conditions.**

2. **Cequent Performance Products** hitches are designed for use with recreational fifth wheel trailers only. Hitch applications other than recreational fifth wheel trailers must be approved in writing by **Cequent Performance Products'** Engineering Department.
3. Use only a SAE 2-inch kingpin with your 20K Fifth Wheel Hitch.
4. Approximately 15%-25% of trailer weight should be on hitch (Pin Weight). See Figure 13.

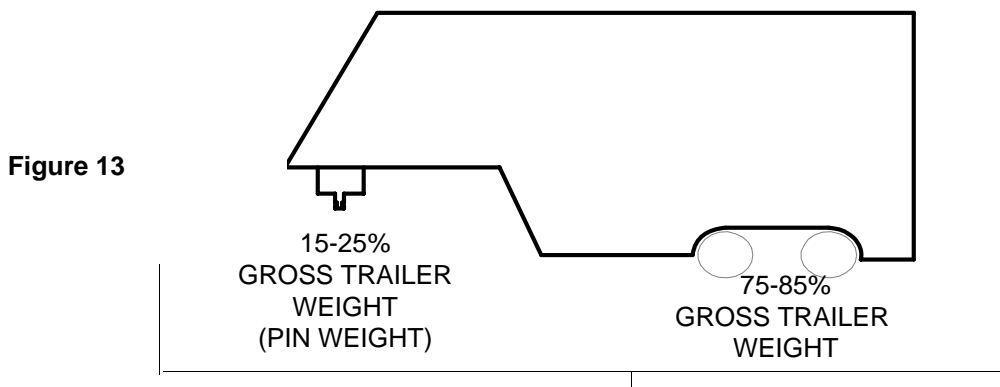

5. Trucks come in many different configurations. **Cequent Performance Products'** hitches are designed for use in light trucks such as the Ford F-Series, the Chevy Silverado and the Dodge Ram. **Cequent Performance Products** recommends the use of long bed (8ft) light trucks for the best combination in truck - trailer turning clearance.

Rule of thumb: The distance from the back of the truck cab to the center of the rear truck axle ("X" in Figure 14), should be approximately 4 inches greater than one-half the trailer width ("Y" in Figure 4)

Figure 14

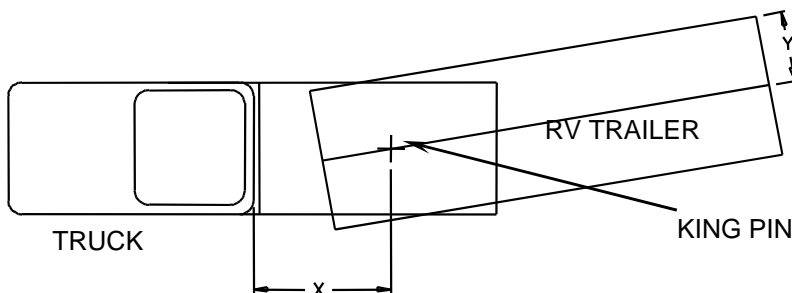

6. If a short bed pickup (less than 8 ft. but longer than 6 ft.) is to be used for towing, **Cequent Performance Products** recommends the trailer be equipped with an extended pin box to help gain additional truck - trailer turning clearance (See trailer manufacturer for options) (Figure 15). It also may be helpful to add a Square Tube or Round Tube Slider (**Part # 30048 / 50008**) for increased turning clearance for low speed, non-highway maneuvering.

Figure 15

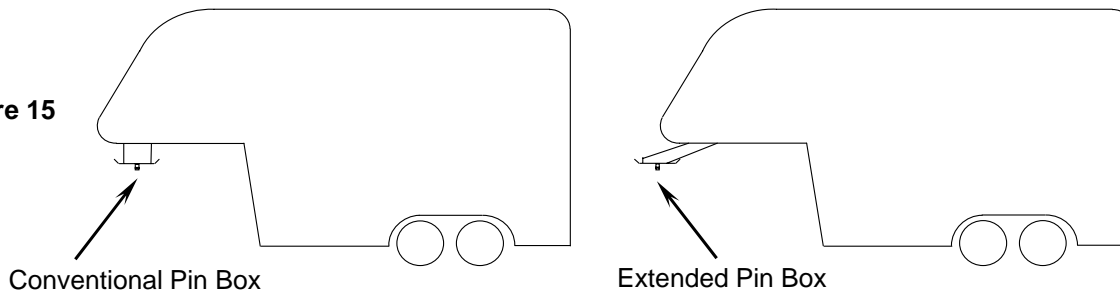

⚠ WARNING:

Do Not install this fifth wheel hitch on or attempt to tow with a short bed pickup truck that has a bed shorter than 6 ft.!

7. The height of the hitch and the pin box should be adjusted so the trailer is approximately level as it is towed. Allow approximately 6 inches clearance between the top of the pickup walls and the underside of the front of the trailer for pitch and roll of the trailer. (Figure 16). Allow more clearance between pickup walls and trailer for off road use.

Figure 16

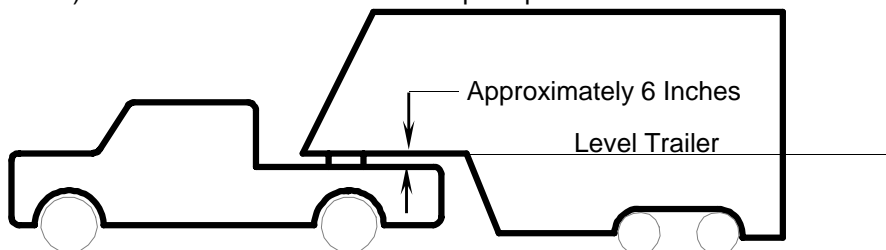

CAUTION:

The measurements above are guidelines. If your measurements are close to these numbers re-check clearances. If vehicle and/or trailer has any added bed vicinity accessories (i.e. fairings, air dams, ground effects, bed rails, etc.). Additional dimensioning and clearance checks have to be made.

8. Hitch height determination:
With trailer leveled and on level ground measure from the ground to the king pin box, "A" in Figure 17. Secondly measure from the height of the inside of the truck bed, "B" in Figure 17. Dimensions "C" and "D" in Figure 17 can be used to determine the amount of clearance over the side rails, as mentioned in Note 17.

$$\text{Hitch Height} = A - B + 2''$$

The 2" value is an estimate of suspension compression due to king pin weight of the trailer. This compression could range between 1"-5" depending on the truck being used and the trailer being towed.

$$D - C + 2'' > 6'' \text{ as noted in Note 7.}$$

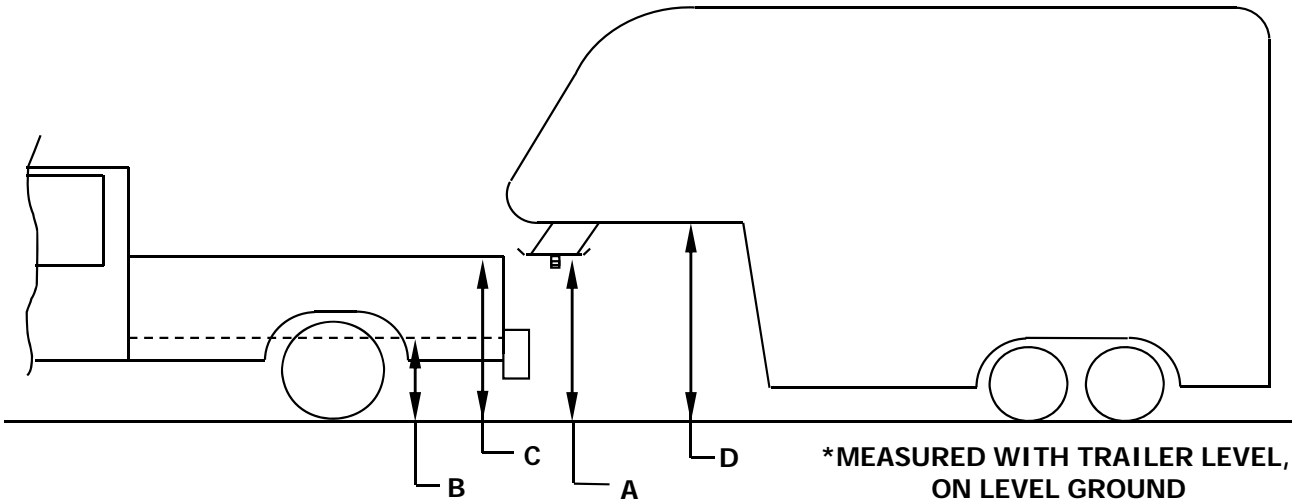

Figure 17

9. If a lube plate is to be used with a 5th Wheel Kit it must be at least 12" in diameter. **Cequent Performance Products** offers this optional lube plate as part # 83001 / 40001.

⚠ WARNING:

- Connection for trailer wiring must be located at the side of the truck bed between the driver's seat and the rear wheel to prevent operators from working between the truck and trailer.
- Avoid putting any part of your body under the trailer or between the truck and trailer. Unexpected or accidental movement of the truck or the trailer can cause serious injury or death
- If you must place any part of your body under the trailer or between the truck and trailer you **MUST** perform **ALL** of the following steps:
 - Check that the truck transmission is in park
 - Check that the emergency brake is on
 - Block in front of and behind all trailer tires
 - Check that the trailer landing gear are resting on firm ground

Appendix B

GUIDELINE FOR CENTER SECTION ORIENTATION

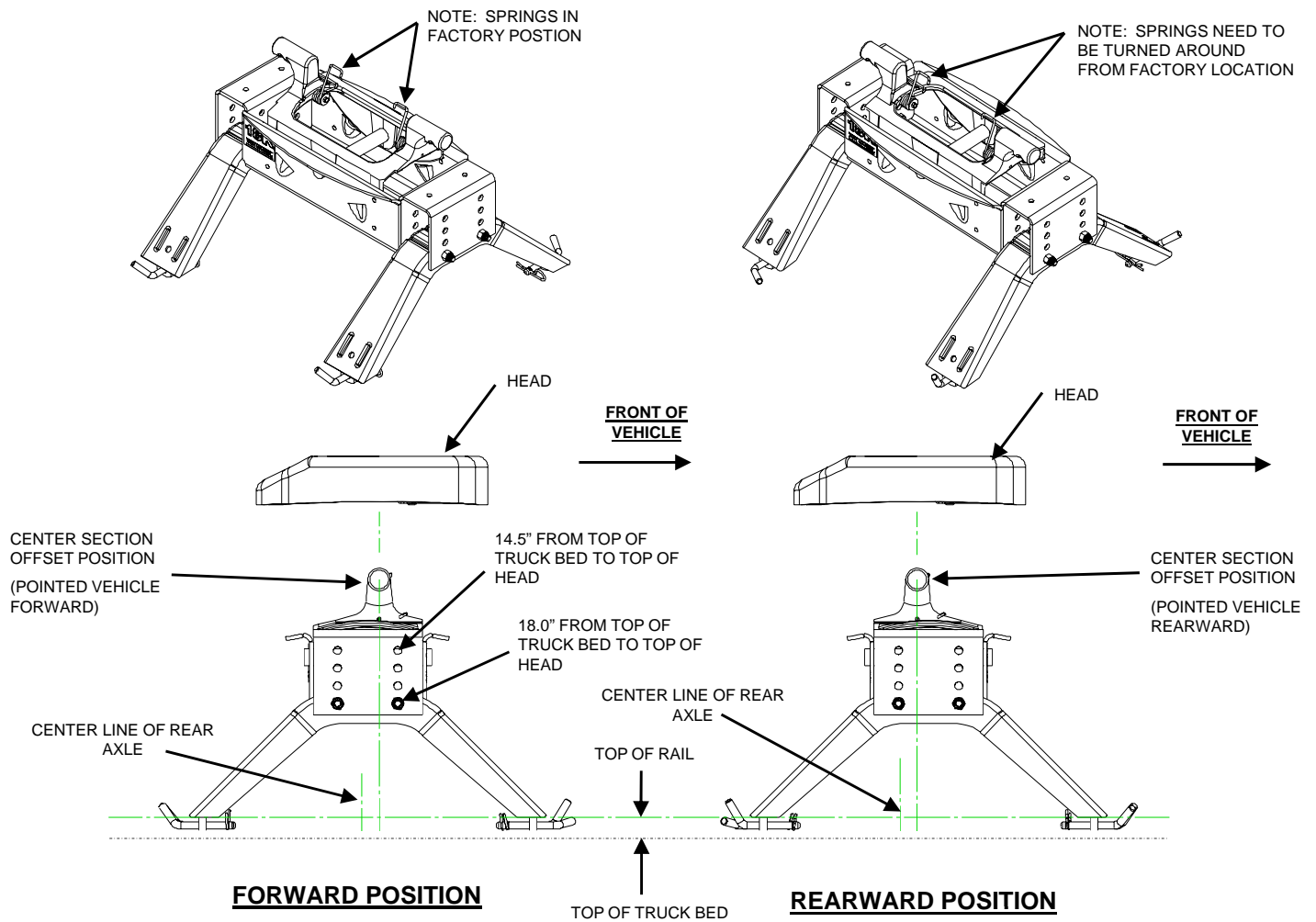

| Manufacture | Year | Vehicle Fit (Bed Length) | Center Section Offset Position |
|---------------|----------------|--------------------------------|--------------------------------|
| Dodge | 1973 - 1993 | (All) | Forward |
| | 1994 - 2004 | Dakota (All) | Forward |
| | 1994 - 2001 | Ram (All) | Forward |
| | 2002 - Present | Ram 1500 (All) | Forward |
| | 2002 - Present | Ram 2500/3500 Heavy Duty (All) | Forward |
| Ford | 1973 - 1996 | F150 (All) | Rearward |
| | 1973 - 1997 | F250/F350 (All) | Rearward |
| | 1997 - 2003 | F150 (All) | Forward |
| | 2004 | F150 Heritage (All) | Forward |
| | 2004 - Present | F150 except Heritage (All) | Forward |
| | 1999 - Present | F250/F350 Super Duty (All) | Rearward |
| GM | 1973 - 1987 | C/K Series (All) | Rearward |
| | 1988 - 2000 | C/K Series (6' Bed) | Forward |
| | 1988 - 2000 | C/K Series (8' Bed) | Forward |
| | 1999 - Present | 1500/2500 Series (6' Bed) | Forward |
| | 1999 - Present | 1500/2500 Series (8' Bed) | Forward |
| | 2001 - Present | 3500 (ALL) | Forward |
| Toyota | 2000 - Present | Tundra (All) | Forward |